



**Subframe Setup & Installation Instructions**  
1967-81 Camaro/Firebird  
1968-74 Nova



## Introduction

Congratulations on the purchase of your Art Morrison Enterprises GT Sport subframe. This subframe is the result of 35+ years of chassis and suspension design experience. In an effort to make your project progress smoothly, we have compiled this booklet containing instructions, notes and tips on removal of your current subframe as well as assembly and installation of your new GT Sport subframe.

### *Suspension Performance*

Art Morrison Enterprises' Engineering department has chosen C5 suspension components for their superior strength, design and aftermarket support. However, simply using C5 parts will not guarantee the best performance. Countless hours were spent utilizing computer modeling and analysis to ensure the suspension provided on this subframe is the best available.

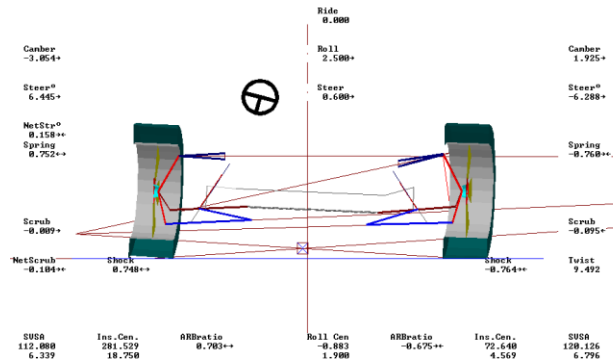

### *Engine Location*

Your new GT Sport subframe will accept small block, big block and LS-series Chevrolet engines. Small block engines will be located in the stock location, while big block engines have been relocated. Stock configuration offsets big block engines to the passenger side, making room for steering boxes and power brake boosters. Since a steering box is no longer utilized, the engine has been centered within the vehicle; this may require the use of a smaller power brake booster or an alternative method of power brake assistance. For proper fitment, LS engines require the use of adapter plates available only from Art Morrison Enterprises; the utilization of adapter plates from other manufacturers may generate clearance issues. F-Body engine accessories (including A/C compressors), usually the most difficult configuration to fit in custom chassis, clear this subframe courtesy of the wider rail design. Corvette, GTO, CTS and truck accessory configurations will also fit.

### *Oil Pan Selection*

The engine oil pan design is critical for proper performance as well as trouble-free installation. The location of the steering rack only allows the use of oil pans that replicate the stock profile under the number one and two cylinders. The use of fabricated aluminum or a highly modified pan may cause interference and require notching for proper fit.

The F-Body LS oil pan has been tested and approved for sufficient clearance; GTO, Corvette and truck pans utilize similar front profiles but should be test-fitted prior to final installation. Corvette pans have a drastically different rear sump, which interferes with the use of AME headers.

Depending on the oil pan design, small and big blocks may require relocation of the steering rack equalizer tube. To relocate the tube, simply rotate both tie rod

boots equally until sufficient clearance is achieved. The tube can also be removed and the boot ties cut to make rotating the boot easier.

### *Manual Transmissions*

This subframe is designed to support modern manual transmissions that use hydraulically actuated clutches. This type of clutch actuation now has excellent aftermarket support and allows for an uncluttered engine compartment while still offering reliable performance.

### *Steering Columns*

To use the stock steering column, a rag joint adapter must be bolted onto the column end to accommodate a universal joint. Due to this process, some stock steering columns may have an interference problem between the universal joint and the frame rail and can be solved by using an aftermarket column that is shorter in length.

A Flaming River steering column was utilized on this installation for several reasons. First, the column can be ordered in any length for maximum flexibility. Second, the welcome addition of a tilt feature and all new components as well as zero steering shaft slop, makes these columns a convenient choice. Third, they feature a 1" double-D end for easy hook-up. Lastly, Flaming River offers steering columns that are 2" wide, which allows you to reuse the factory firewall mount and Flaming River's optional dash mount for a true bolt-in installation. A steering linkage kit that provides you with all the necessary parts to connect an aftermarket column to the steering rack is available from Art Morrison Enterprises.



First generation cars will work well with a 32" long steering column. This puts the steering wheel approximately in the same position as a stock column, and provides sufficient clearance between the universal joint and frame rail. To replicate the stock steering column position, place the steering-wheel end 12-1/2" to 13-1/2" from the center of the dash mount fasteners (First gen. only).

### *Brake Lines*

The GT Sport subframe will accommodate the use of OEM rear brake lines with minor modifications; however, the front lines will not fit. Art Morrison Enterprises offers a front line kit to make this task easier, and includes all necessary fittings and clamps to provide fluid to the brake calipers. Due to the variety of braking systems, a short line will need to be fabricated from the master cylinder (or combination valve) to the front line kit.

### *Body Mount Selection*

There are many body mount choices available; mounts can be obtained in OEM-style rubber, polyurethane or solid aluminum and can be full or half-height. For the utmost in precision handling and an eye-catching stance, Art Morrison Enterprises produces half-height 6061-T6 aluminum body mounts.

Rubber or polyurethane mounts should be used when a higher level of comfort is desired. Because they allow the subframe to move independently from the body, they should not be used with subframe connectors. Solid aluminum bushings provide a ridged connection between the subframe and body and are required when using subframe connectors.

### *Subframe fit and OEM tolerances*

Art Morrison Enterprises has done extensive testing to ensure the subframe matches OEM specifications while maintaining much tighter tolerances than GM's specifications as produced over 35 years ago.

Over those years, these vehicles have been subjected to high miles, accidents, racing and lastly, time. Many of these vehicles have been in accidents, damage from which are no longer readily evident, however these incidents may have severely distorted the location of body mounts. Even low mileage, pristine "survivor cars" can suffer from body sag due to uneven spring settling. Due to these factors, the body mounts located on the subframe may be slightly different than those on the body shell. This is considered normal, and is often not an issue thanks to a large amount of adjustability.

### **Removal of old subframe**

Removing the stock clip is fairly straightforward. This section will proceed with the assumption that the engine and transmission has already been removed and the front body panels will remain on the vehicle. However, if the engine is to be removed with the stock subframe, removal of the grill and valence panels will make the job much easier and the fenders can still remain on the car.

If a lift is not available, raise the entire vehicle as high as possible and support the car with jackstands under the rocker panels. Next, remove all fluid lines and cables from the subframe (don't forget ground straps!). These can be left hanging until the new subframe is installed, although now is an excellent time to replace these critical items if you haven't already done so.

To make the installation of the new subframe easier, the steering column should be removed. This is done by removing the two firewall support halves and loosening the rag joint from the steering box. A small shot of penetrating oil may be needed on the steering box shaft to loosen the rag joint. Now, disconnect all wiring from the column, remove the two nuts near the dash panel and pull the column out.

Lastly, remove the bumper mounts from the subframe. The bumper can remain bolted to the car with the two brackets attached to the fenders. Now, place a hydraulic jack under the engine crossmember and begin removing the six subframe bolts starting with the front two ½" bolts at the core support. Remove the remaining four bolts beginning with the two fasteners near the firewall with a

*Revised 11/30/2011 MJ*

helper supporting the rear of the subframe. Begin lowering the subframe and roll it out from beneath the vehicle.

### **Installation & Setup**

This manual will provide installation tips with the premise that the front sheetmetal has not been removed from the vehicle. To make installation easier, two hydraulic jacks can be used; one placed under the front suspension crossmember, and the other placed under the transmission mount. The jacks can be raised in unison to the body then the subframe can be loosely bolted into place. A small gap should remain between the underbody and body mount to allow movement for subframe alignment.

It is imperative that the subframe is trial fitted before it is painted or coated. Now is an excellent time to install brake lines, ground straps, fuel lines, etc. Putting in extra time at this stage will pay big dividends later.

### *Component Installation*

At this stage brake lines, fuel lines, parking brake cables, etc. should be attached. To prevent interference later, it is imperative to be mindful of where the engine and headers will sit.

Fuel lines may be routed along the subframe as on the original subframe, although minor bends may be required to ensure the line lies flush against the frame rail. Once the location is satisfactory, secure the line into place and mark the rail for clamp locations.

Because a Wilwood pedal assembly with balance bar is used in this installation



(shown at left), the rear line will need to be modified. Again, minor bends are made to the stock line to fit the new subframe. Stock brake systems can utilize the stock complete rear brake line, but steps should be taken to affix the line to the subframe. If the optional front brake line kit is being used, attach the line with the provided clamps at this time.

Careful attention should be spent on the clearance between the rear upper control arm bushing and the wheel well skirt. If an interference or clearance issue exists, simply bend the skirt until sufficient clearance is made.



### *Painting/Powdercoating*

Prior to finishing, the subframe should be disassembled. It is highly recommended that the upper control arm, lower control arm, and knuckle be removed as one piece to prevent any error during reassembly. Also, the steering rack should be removed with the tie rod ends attached to maintain the proper toe setting.



Ideally, all welding and drilling should be completed prior to powdercoating or painting.

Please note that all welds must not be ground smooth, as this will weaken the subframe's structural integrity. If you wish to have the welds smoothed, use body filler instead.

### *Final Assembly*

After the finishing operation has been completed, the subframe can now be assembled. Set the subframe on a level surface (preferably on jackstands) in a well-lit area. Next, use a rat-tail file to clean all holes which bolts pass through and make sure all threaded bosses are clear of powder or paint. To finish the preparation process, collect all fasteners and verify that sufficient anti-seize remains on the threads. Apply more if necessary.



To begin assembling, install the upper control arm/knuckle/lower control arm assembly by first fastening the lower control arm bolts to the subframe. Next, bolt the upper control arm to the frame ensuring that the alignment bushings lay between the two. Hand-tighten all fasteners for now and repeat the process on the opposite side. Now, install the steering rack with the fasteners hand-tighten and attach the tie rod end to the knuckle. To install the sway bar, first attach the end linkage to the bar using the drawing as a guide. Then attach the linkage to the control arm and rotate the bar towards the bottom of the frame for attachment. To mount the coilovers, attach the lower mount to the control arm with the provided fasteners and then attach the upper mount to the chassis. Once this is accomplished, tightened all fasteners to specifications (torque values listed below).

*Revised 11/30/2011 MJ*

The steering racks are available in 15:1 and 20:1 ratios. Racks equipped with a 20:1 ratio gear is intended for long distance cruising and comfort, while 15:1 racks should be utilized in performance-oriented applications only. When plumbing the steering rack, note the fitting closest to the radiator is the pressure line, while the other is the return. To start the bleeding process, first fill the reservoir full of power steering fluid (**Note: Do NOT use ATF, damage will result!**). With the reservoir cap removed and the wheels off the ground, turn the steering wheel lock-to-lock twenty times while monitoring the fluid level. When complete, the engine can be started and checked for leaks. Before driving for the first time, rotate the steering wheel another four times.

To complete the assembly process, attach any brake lines, brackets, transmission crossmember and other necessary components.

### *Aligning the Subframe*

OEM subframes are easily aligned on the assembly line by using fixtures and two locator pins. Without the fixtures used by Chevrolet, the locator pins only serve as a rough guide and the subframe will still need to be properly aligned. The method utilized in this manual will align the subframe to the rear suspension by eliminating the potential alignment misgivings caused by distortion of the body due to accidents or body sag. This ensures the front and rear suspension is aligned to each other.

To align the subframe, first install these items on both the driver and passenger side:

- ✓ Upper control arms
- ✓ Lower control arms
- ✓ Knuckles

Next, raise the knuckle to the approximate ride height (hub centerline even with bottom of chassis main rail), and set to zero toe. Zero toe is simply rotating the knuckle until the hub face is square with the chassis. This can be done by clamping a 2' length of angle iron to the hub, and measuring from each end to a flat area on the chassis. When the measurements from both sides are equal, the hub is square.

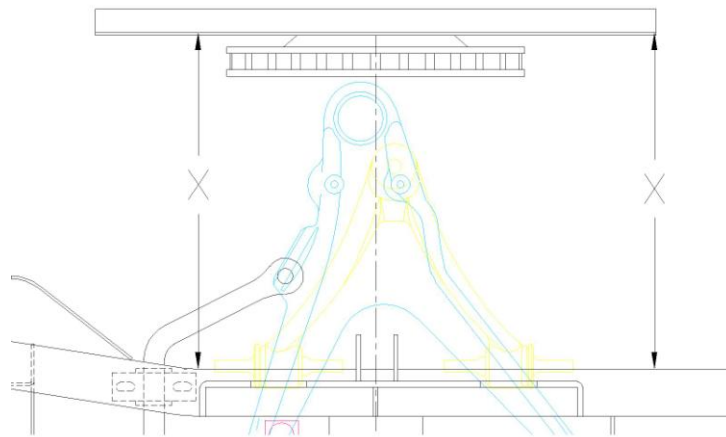

To ensure accuracy also raise the rear axle to the approximate right height. Now, check the wheelbase at both sides, and move the subframe until the wheelbase is 108" +/- 1/4". If the subframe is difficult to move, slightly loosen the mounting bolts. Ultimately, fender placement and personal preference may dictate where the spindle centerline will be.

*Revised 11/30/2011 MJ*

Once the wheelbase is satisfactory, it is time to check squareness between the body and subframe. Proper datums to use are the lower control arm bolt heads and either the leaf spring locating pins or the alignment holes located on the rear frame rails just ahead of the front spring mount. Measure diagonally between these points and adjust the subframe until both measurements are within 1/8". The subframe can be adjusted slightly by a firm hit with the palm of your hand or a rubber mallet. Once the measurements are square, re-check the wheelbase. If the wheelbase remains within tolerance, tighten the subframe mounting bolts. If not, repeat the alignment process.

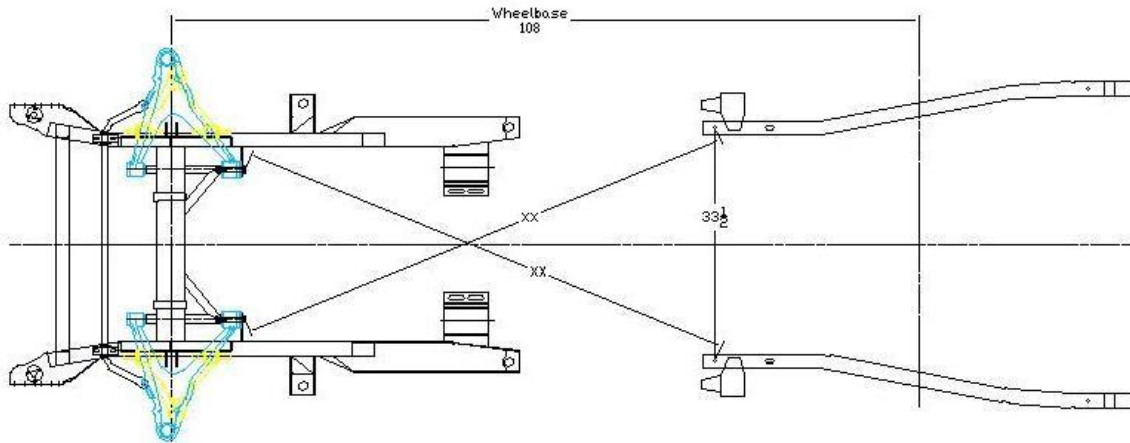

*Squaring the chassis with the body*

### *Emergency Brake*

If an emergency brake is to be used, an aftermarket cable system is recommended as it allows more flexibility and often a better appearance. However, if your budget does not allow this, the OE front cable can be made to work by fabricating simple brackets. Shown below is one method using the OE front cable.

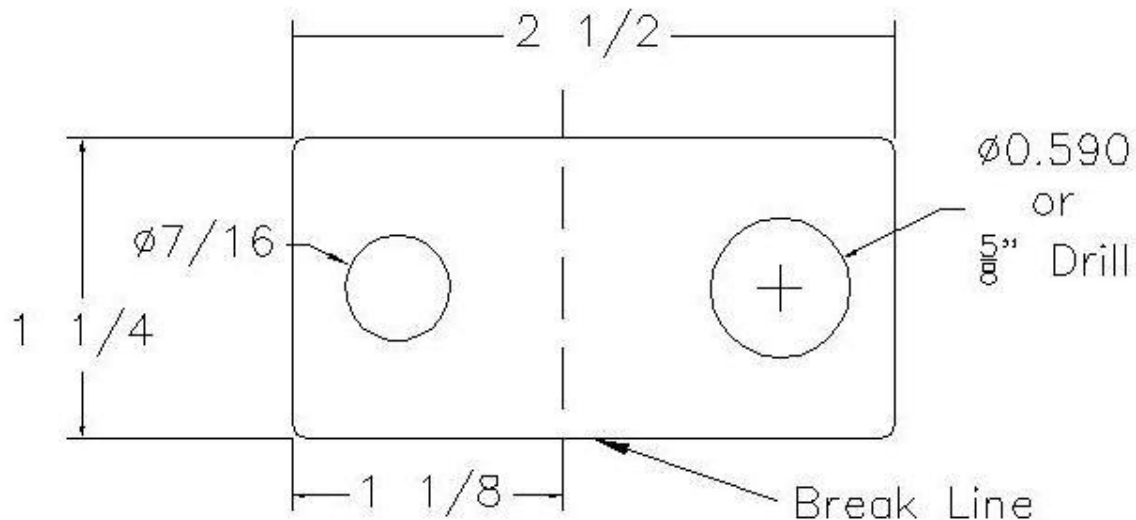

This simple bracket is fabricated from 1-1/4"x1/8" steel flat stock cut to 2-1/2" in length. A 5/8" and 7/16" hole is drilled on the ends, then bent to 90\*. A common brake hose retainer is used to fasten the cable to the bracket and is then bolted to the transmission mount.

Since this system will not use the original support bracket for the intermediate cable, a custom cable will have to be made that is shorter in length. A piece of string can be used as a mock-up to determine the length of the new cable.

#### *Rotor and Pad Break-in*

If you purchased the optional Wilwood brake kit, it is imperative the break-in procedure be followed very carefully. Failure to follow these directions will lead to glazed pads and poor braking performance. If these directions are missing from your brake kit, contact our tech staff.

#### *100-Mile Checkup*

After the first 100 miles, please check these items:

1. All fasteners (including wheel lugs)
2. Brake fluid
3. Power steering fluid
4. Coolant
5. Transmission fluid (if applicable)
6. Fuel lines
7. Brake Lines
8. Brake flex hoses
9. Battery cables
10. Exhaust system

The coil springs should also be checked and readjusted if necessary. New springs will typically settle once after several miles and usually do not need a second adjustment.

<b>Fastener Torque Specifications</b>			
<i>Fastener</i>	<i>Location</i>	<i>Torque Value</i>	<i>Lubrication</i>
14mmx1.5	LCA	50 lb-ft	Anti-seize
5/8"-NF	Steering Rack	55 lb-ft	Anti-seize
7/16"-NC	Transmission Crossmember	40-lb-ft	Dry
3/8"-NF	UCA, Lower sway bar link	30 lb-ft	Dry
3/8"-NC	Sway bar to frame bushing	27 lb-ft	Dry
<p><i>Notes:</i>  <i>Torque values without lubrication should be reduced by 15% for SAE30 oil or equivalent, 20% for anti-seize. Values shown are adjusted for lubrication type.</i></p> <p><i>Blue thread locking compound or mechanical methods should be used on all fasteners wherever possible.</i></p>			